

NEW!

VOLVO PENTA GENSET ENGINE

TAD1241GE

1500 rpm, 354 kW (481 hp)
1800 rpm, 387 kW (526 hp)

The TAD1241GE is a powerful, reliable and economical Generating Set Diesel Engine built on the dependable in-line six design.

Durability & low noise

Designed for easiest, fastest and most economical installation. Well-balanced to produce smooth and vibration-free operation with low noise level.

To maintain a controlled working temperature in cylinders and combustion chambers, the engine is equipped with piston cooling. The engine is also fitted with replaceable cylinder liners and valve seats/guides to ensure maximum durability and service life of the engine.

Low exhaust emission

The state of the art, high-tech injection and charging system with low internal losses contributes to excellent combustion and low fuel consumption.

The TAD1241GE complies with EPA/CARB Tier 2 and TA-Luft -50% exhaust emission regulations.

Easy service & maintenance

Easily accessible service and maintenance points contribute to the ease of service of the engine.

Technical description:

Engine and block

- Optimized cast iron cylinder block with optimum distribution of forces without the block being unnecessarily heavy.
- Wet, replaceable cylinder liners
- Piston cooling for low piston temperature and reduced ring temperature
- Tapered connecting rods for reduce risk of piston cracking
- Crankshaft induction hardened bearing surfaces and fillets with seven bearings for moderate load on main and high-end bearings
- Case hardened and nitrocarburized transmission gears for heavy duty operation
- Keystone top compression rings for long service life
- Viscous type crankshaft vibration dampers to withstand single bearing alternator torsional vibrations
- Replaceable valve guides and valve seats
- Over head camshaft and four valves per cylinder

Lubrication system

- Full flow oil cooler
- Full flow disposable spin-on oil filter, for extra high filtration
- The lubricating oil level can be measured during operation
- Gear type lubricating oil pump, gear driven by the transmission

Fuel system

- Non-return fuel valve
- Electronic Unit Injectors
- Fuel prefilter with water separator and water-in-fuel indicator / alarm
- Gear driven low-pressure fuel pump
- Fine fuel filter with manual feed pump and fuel pressure switch
- Fuel shut-off valve, electrically operated

Cooling system

- Air to air intercooler
- Coolant filter as standard
- Gear driven, maintenance-free coolant pump with high degree of efficiency

- Efficient cooling with accurate coolant control through a water distribution duct in the cylinder block. Reliable sleeve thermostat with minimum pressure drop

Turbo charger

- Efficient and reliable turbo charger
- Extra oil filter for the turbo charger

Electrical system

- Electronical Diesel Control III (EDCIII), an electronically controlled processing system which optimizes engine performance. It also includes advanced facilities for diagnostics and fault tracing
- Three different ways for the customer to connect his controls and instrument to the engine. CAN SAE J1939 interface, CIU (Control interface unit) and Stand alone connections.
- Sensors for oil pressure, oil temp, boost pressure, boost temp, coolant temp, fuel temp, water in fuel, fuel pressure and two speed sensors.

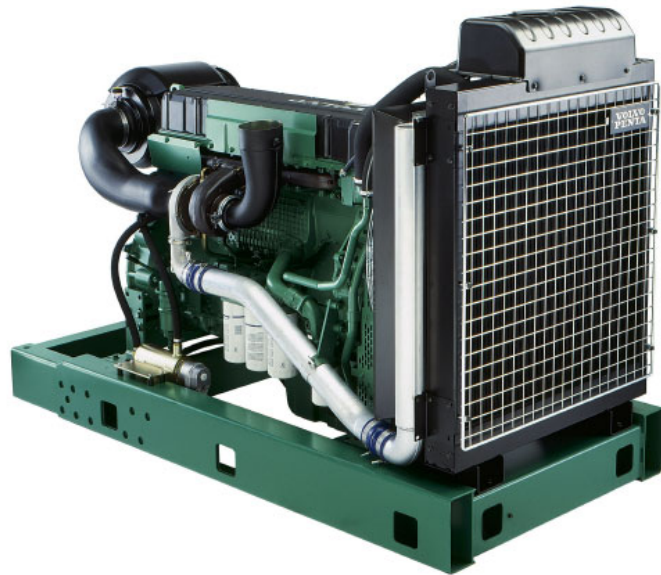

Features

- Maintained performance, air temp 40°C
- Tropical cooling system (55°C)
- Fully electronic with Volvo Penta EDC III
- Dual frequency switch (between 1500 rpm and 1800 rpm)
- High power density
- Emission compliant
- Low noise levels
- Gen Pac configuration

**VOLVO
PENTA**

TAD1241GE

Technical Data

General

| | | |
|--|---------------|--|
| Engine designation | TAD1241GE | |
| No. of cylinders and configuration | in-line 6 | |
| Method of operation | 4-stroke | |
| Bore, mm (in.) | 131 (5.16) | |
| Stroke, mm (in.) | 150 (5.91) | |
| Displacement, l (in ³) | 12.13 (740.2) | |
| Compression ratio | 17.5:1 | |
| Dry weight, kg (lb) | 1380 (3036) | |
| With Gen Pac, kg (lb) | 1645 (3627) | |
| Wet weight, kg (lb) | 1455 (3201) | |
| With Gen Pac, kg (lb) | 1720 (3792) | |

Performance

| | | |
|-------------------|-----------------|-----------------|
| with fan, kW (hp) | 1500 rpm | 1800 rpm |
| Prime Power | 323 (439) | 352 (479) |
| Max Standby Power | 354 (481) | 387 (526) |

Lubrication system

| | | |
|---|-----------------|-----------------|
| Oil consumption, liter/h (US gal/h) | 1500 rpm | 1800 rpm |
| Prime Power | 0.11 (0.029) | 0.12 (0.032) |
| Max Standby Power | 0.12 (0.032) | 0.13 (0.034) |
| Oil system capacity incl filters, liter | 35 | |
| Oil change intervals at specification | | |
| VDS-2, h | 600 | |
| VDS, ACEA E3, h | 400 | |
| ACEA E1, E2, API CD, CF, CF-4, CG-4, h | 200 | |

Fuel system

| | | |
|-----------------------------------|-----------------|-----------------|
| Specific fuel consumption at | | |
| Prime Power, g/kWh (lb/hph) | 1500 rpm | 1800 rpm |
| 25 % | 216 (0.350) | 231 (0.374) |
| 50 % | 199 (0.323) | 208 (0.330) |
| 75 % | 195 (0.316) | 200 (0.324) |
| 100 % | 198 (0.321) | 202 (0.327) |
| Max Standby Power, g/kWh (lb/hph) | 1500 rpm | 1800 rpm |
| 25 % | 211 (0.347) | 225 (0.365) |
| 50 % | 197 (0.319) | 203 (0.329) |
| 75 % | 195 (0.316) | 200 (0.324) |
| 100 % | 199 (0.323) | 203 (0.329) |

Intake and exhaust system

| | | |
|--|-----------------|-----------------|
| Air consumption at 27°C, m ³ /min (cfm) | 1500 rpm | 1800 rpm |
| Prime Power | 23.5 (830) | 28.0 (989) |
| Max Standby Power | 25.0 (883) | 29.0 (1024) |
| Max allowable air intake restriction, kPa (In wc) | 5 (20.1) | |
| Heat rejection to exhaust, | | |
| kW (BTU/min) | 1500 rpm | 1800 rpm |
| Prime Power | 250 (14217) | 272 (15468) |
| Max Standby power | 276 (15696) | 306 (17402) |
| Exhaust gas temperature after turbine, | | |
| °C (°F) | 1500 rpm | 1800 rpm |
| Prime Power | 490 (914) | 465 (869) |
| Max Standby Power | 505 (941) | 490 (914) |
| Max allowable back-pressure in exhaust line, kPa (In wc) | 10 (40.2) | |
| Exhaust gas flow, m ³ /min (cfm) | 1500 rpm | 1800 rpm |
| Prime power | 58 (2048) | 66 (2331) |
| Max Standby Power | 63 (2225) | 72 (2543) |

Cooling system

| | | |
|--|-----------------|-----------------|
| Heat rejection radiation from engine, | | |
| kW (BTU/min) | 1500 rpm | 1800 rpm |
| Prime Power | 17 (967) | 18 (1024) |
| Max Standby Power | 18 (1024) | 20 (1137) |
| Heat rejection to coolant kW (BTU/min) | | |
| Prime Power | 123 (6995) | 139 (7905) |
| Max Standby Power | 125 (7109) | 143 (8132) |
| Fan power consumption, kW (hp) | 9 (12) | 15 (20) |

Standard equipment

| | Engine | Gen Pac |
|---|-----------------|---------|
| Engine | | |
| Automatic belt tensioner | • | • |
| Lift eyelets | • | • |
| Flywheel | | |
| Flywheel housing with conn. acc. to SAE 1 | • | • |
| Flywheel for 14" flex. plate and flexible coupling | • | • |
| Vibration dampers | • | • |
| Engine suspension | | |
| Fixed front suspension | • | • |
| Lubrication system | | |
| Oil dipstick | • | • |
| Full-flow oil filter of spin-on type | • | • |
| By-pass oil filter of spin-on type | • | • |
| Oil cooler, side mounted | • | • |
| Low noise oil sump | • | • |
| Fuel system | | |
| Fuel filters of disposable type | • | • |
| Electronic unit injectors | • | • |
| Pre-filter with water separator | • | • |
| Intake and exhaust system | | |
| Air filter without rain cover | • | • |
| Air filter with replaceable paper insert | • | • |
| Air restriction indicator | • | • |
| Air cooled exhaust manifold | • | • |
| Connecting flange for exhaust pipe | • | • |
| Exhaust flange with v-clamp | • | • |
| Turbo charger, low right side | • | • |
| Crankcase ventilation | • | • |
| Cooling system | | |
| Tropical radiator incl intercooler | • ¹⁾ | • |
| Gear driven coolant pump | • | • |
| Fan hub | • | • |
| Thrust fan | — | • |
| Fan guard | — | • |
| Belt guard | — | • |
| Control system | | |
| Engine Management System (EMS) with CAN-bus interface SAE J1939 and stand alone interface | • | • |
| Alternator | | |
| Alternator 60A / 24 V | • | • |
| Starting system | | |
| Starter motor, 6.0kW, 24 V | • | • |
| Connection facility for extra starter motor | • | • |
| Instruments and senders | | |
| Temp.- and oil pressure for automatic stop/alarm 103°C | • | • |
| Other equipment | | |
| Expandable base frame | — | • |
| Engine Packing | | |
| Plastic warpping | • | • |

¹⁾ must be ordered, see order specification - optional equipment
 — optional equipment or not applicable
 • included in standard specification

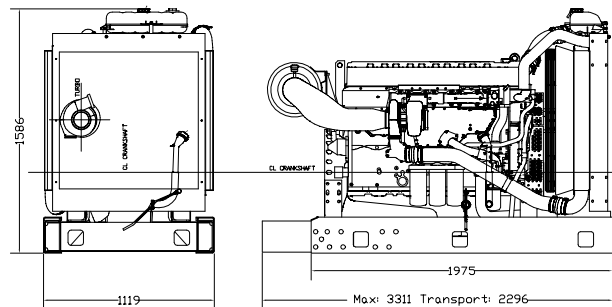

Note! The engine illustrated may not be entirely identical to production standard engines.

Power Standards

The engine performance corresponds to ISO 3046, BS 5514 and DIN 6271. The technical data applies to an engine without cooling fan and operating on a fuel with calorific value of 42.7 MJ/kg (18360 BTU/lb) and a density of 0.84 kg/liter (7.01 lb/US gal), also where this involves a deviation from the standards. Power output guaranteed within 0 to +2% at rated ambient conditions at delivery. Ratings are based on ISO 8528. Engine speed governing in accordance with ISO 3046/IV, class A1 and ISO 8528-5 class G3

Exhaust emissions

The engine complies with EPA / CARB - Tier 2 and TA-luft -50% exhaust emission regulations.

Rating Guidelines

PRIME POWER rating corresponds to ISO Standard Power for continuous operation. It is applicable for supplying electrical power at variable load for an unlimited number of hours instead of commercially purchased power. A10 % overload capability for governing purpose is available for this rating. MAXIMUM STANDBY POWER rating corresponds to ISO Standard Fuel Stop Power. It is applicable for supplying standby electrical power at variable load in areas with well established electrical networks in the event of normal utility power failure. No overload capability is available for this rating.
 1 hp = 1 kW x 1.36

Information

For more technical data and information, please look in the Generating Set Engines Sales Guide.

VOLVO PENTA

AB Volvo Penta
 SE-405 08 Göteborg, Sweden
 www.volvopenta.com